

## PRESSURISATION UNITS

### FEATURES

- Used for pressurising chilled water system in HVAC applications.
- Provides make up water to pressurise the water system.
- Double pump, (1 working + 1 stand-by).
- Microprocessor based control panel with dry run protection & duty cycling.
- Multistage centrifugal type pumps - quiet, reliable and rugged.
- Flow meter to measure the make up water quantity.
- All Components, i.e. pumps, pressure transmitter, flow meter, interconnecting piping and control panel factory mounted on a compact steel frame.

### BENEFITS

- Ensures positive pressure throughout the system thus preventing vapour/air locks.
- Automatic operation.
- BMS Compatible option.

### TECHNICAL DATA

Model	:	PSU-225	PSU-225	PSU-260	PSU-2100	PSU-2150
Pump						
Type	:	..... Multistage, Centrifugal .....				
Power(KW)	:	0.55	0.55	1.1	1.5	2.2
Power supply (AC, 50Hz)	:	230V, 1Ph .....		415V, 3Ph .....		
Max. flow rate (CMH)	:	2	2	2	2	2
Max. head (mWC)	:	25	25	60	100	150
Pressure rating	:	PN10	.....	PN16	.....	PN20
Max. fluid temp.	:	..... 70°C .....				
Protection	:	..... IP55 .....				
Controls						
Pressure range	:	..... 0 to 10 bar .....		..... 0 to 25 bar .....		
Pressure differential	:	..... 1 bar .....				
Control panel protection	:	..... IP55 .....				

## INSTALLATION AND COMMISSIONING

1. Mount on a PCC foundation.
2. Connect water supply to the inlet connection.
3. Connect outlet to the expansion tank.
4. Control Panel's (fig.1) functions are described below:

- ① **Set Point** - The Set point of the pressure is set by up and down key, on pressing any key display starts blinking and shows the set-point. It again shows the actual pressure when it is left idle for 15secs.
- ② **Auto Mode** - Pump switches OFF when the pressure exceeds the set-point and is switched ON, as the pressure goes below (one bar) the set-point. If the pressure is not achieved in 15mins, the pump will switch OFF and after 1min other pump will start to achieve the required pressure.
- ③ **Manual Mode** - Operation can be switched from Auto mode to Manual mode for Pump 1 / Pump 2 by the toggle switch. In manual mode, the pump operates continuously for 30mins, then stops for 10mins before restarting.
- ④ **Alarm** - A NO contact of relay is provided for the alarm which closes when an alarm is raised. In case of alarm, press reset key to clear alarm or switch OFF & then switch ON the mains.

## DIMENSIONS

	PSU-225 (PN10)	PSU-225 - 2100 (PN16)	PSU-2150 (PN20)
<b>L</b>	500	1050	1050
<b>W</b>	540	700	700
<b>H</b>	580	830	1050

All dimensions are in mm

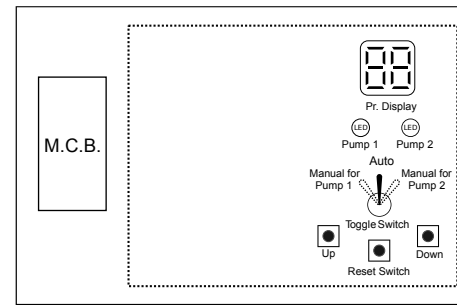

**Fig.1 Control Panel**

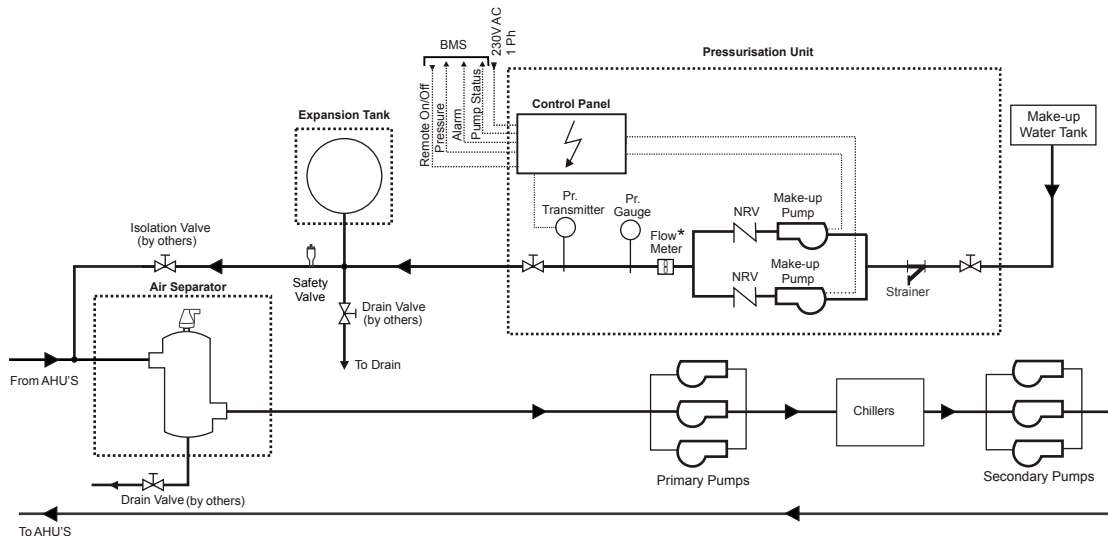

**Fig.2 Schematic drawing of pressurisation unit, expansion tank and air separator.**

\* Flow Meter not included with PN20 units.